

## GMC-U60 Magnetic Touch Latch

### Features

- Push to open/close
- Mortise type
- For overlay doors: can be embedded in the edge of side board, etc.

### Notes

- Provide a  $\phi 15$  counterbore of 3 ~ 5 mm deep at the door for installing the counter plate (for the relation between counterbore depth A and door clearance B, see "Cut Out Dimensions" in the lower left)
- For small overlay door, not advisable for large doors
- Use hinges without catch

### Parts Included

- Counter plate **GW12**
- Pan head wood screw 2.9x13
- Countersunk head wood screw 3.8x16

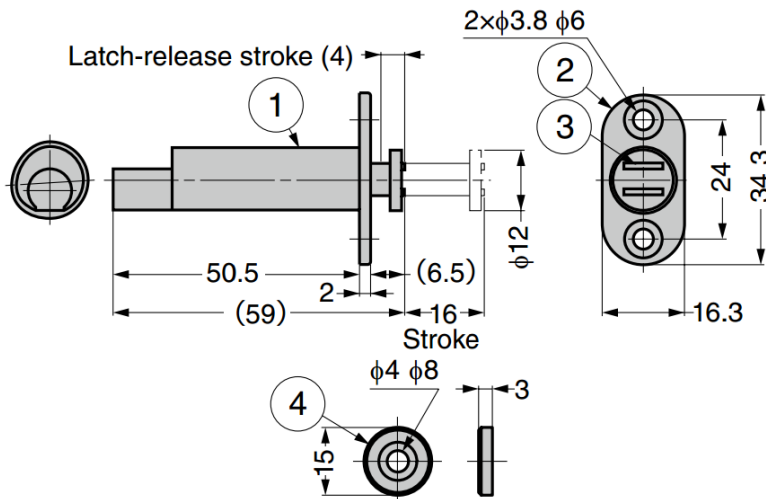
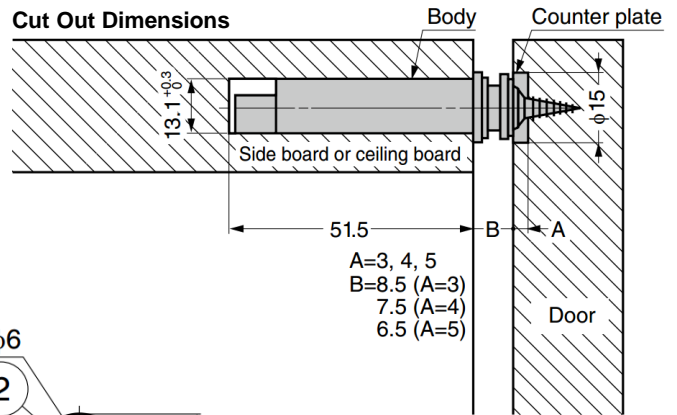

No.	Part Name	Material	Finish / Colour
①	Body	ABS/POM	Brown
②	Mounting Plate	Stainless Steel (SUS430)	-
③	Yoke	Steel (SPCC)	Nickel
④	Counter Plate	Steel (SUM)	

Part No.	Magnetic Force	
<b>GMC-U60</b>	10.8 N	1.1 kg